

**The Henryk Niewodniczański  
INSTITUTE OF NUCLEAR PHYSICS  
Polish Academy of Sciences  
152 Radzikowskiego str., 31-342 Kraków, Poland**

[www.ifj.edu.pl/reports/2006.html](http://www.ifj.edu.pl/reports/2006.html)

Kraków, July 2006

---

**Report No. 1990/PH**

**A proposal for the mechanical design  
of the LumiCal detector**

J. Błocki, W. Daniluk, M. Gil, A. Moszczyński, K. Oliwa,  
B. Pawlik, L. Suszycki<sup>1</sup>, W. Wierba, L. Zawiejski

on behalf of the FCAL collaboration<sup>2</sup>

**Abstract**

The LumiCal calorimeter [1] will be located in very forward region of the future detector at the International Linear Collider (ILC) [2]. It is composed of tungsten plates and thirty silicon detector planes. It will be used for precisely luminosity measurement. The requirement for the position stability of the silicon detectors is very high. The actual position of each silicon detector plane relative to each other and of the calorimeter relative to the beam line and the interaction point should be known with accuracy of a few micrometers. To achieve this goal the structure of the calorimeter has to be very stiff. Moreover, the support and the temperature of the calorimeter have to be stable.

The aim of this paper is to describe the mechanical structure of the detector which can fulfill the requirement of the structure stiffness. For the proposed structure appropriate calculations of deformations under the dead load have been carried out. From presented here results of calculations it is concluded that the proposed structure can be accepted from the stiffness point of view.

---

<sup>1</sup> AGH, University of Science and Technology, Cracow

<sup>2</sup> list of authors can be found: <http://www-zeuthen.desy.de/ILC/fcal/>

## 1. Introduction

The LumiCal detector is expected to give a required precision luminosity measurement and to extend calorimetric coverage of small angles of electron emission from 26 to 84 mrad. The luminosity measurement will be based on detection of Bhabha event rate and a relative precision of the integrated luminosity of  $10^{-4}$  will be enable [3]. A precise measurement of the scattering polar angles requires an ultimate stiffness and precision in detector mechanical construction and metrology.

## 2. LumiCal Envelope

An envelope for the calorimeter is the following. In the radial direction, the minimal radius is 100 mm and the maximal one is 320 mm. Along the beam, it will be positioned between  $Z = 2300$  mm and  $Z = 2500$  mm, where the interaction point is at  $Z = 0$ . Dimensions of the active part of the LumiCal detector are shown in Fig. 1. This figure illustrates the design of the very forward region at the Large Detector Concept (LDC) [1].

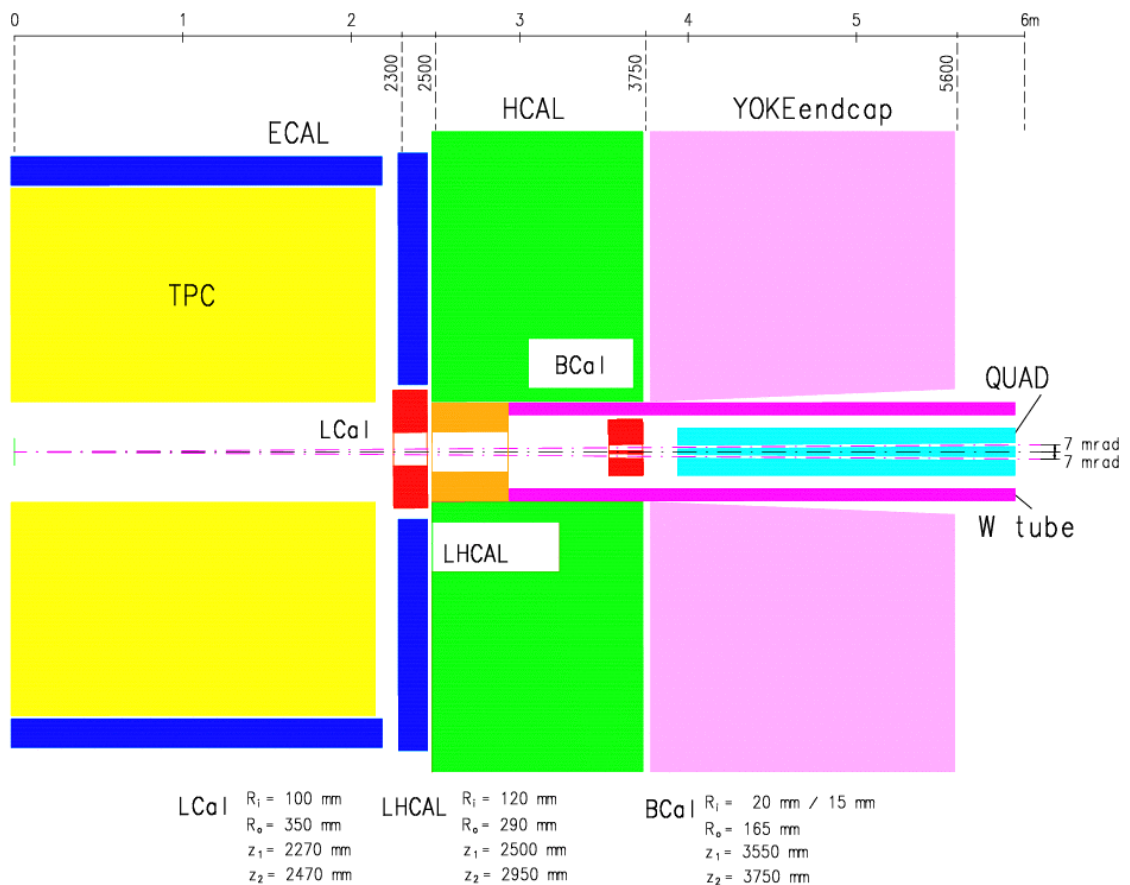

Fig.1. The LumiCal envelope.

### 3. Description of the proposed design

On both sides of the interaction point there will be one LumiCal detector. Each calorimeter is in a form of a barrel which is divided into two parts along the vertical plane. To define the center of gravity of one part of the detector the following formulae has been used

$$x_s = \frac{4}{3\pi} \cdot \frac{R_2^3 - R_1^3}{R_2^2 - R_1^2}.$$

For  $R_2 = 320$  mm and  $R_1 = 100$  mm, we have  $x_s = 146$  mm, as it is shown in Fig. 2. It is assumed that there are two support points for the half of the barrel in an equal distance (68 mm) from the gravity center in the horizontal direction (see Fig.2).

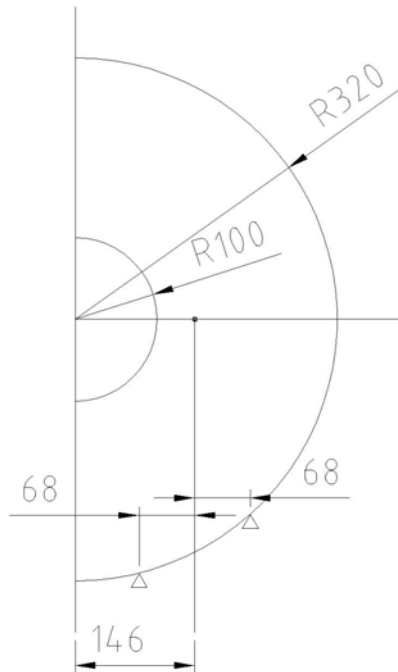

Fig.2. The position of the gravity center.

In fact, for each tungsten plate a plane of the division into two parts is not along the vertical plane but rather along a plane which is rotate around the central axis of the barrel by +7.5 deg or -7.5 deg as it is shown in Fig. 3 and Fig. 4, respectively.

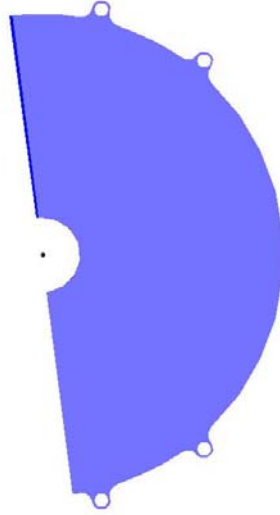

Fig. 3. The tungsten plate (+7.5 deg).

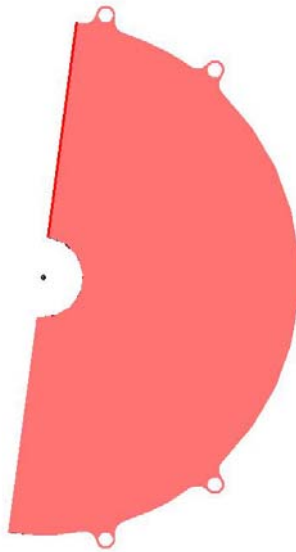

Fig. 4. The tungsten plate (-7.5 deg).

It has to be pointed out that the tungsten plate (+7.5 deg) has the same shape as the tungsten plate (-7.5 deg). It means, that the barrel is composed of only one type of the tungsten plate. To assemble the calorimeter we need two types of rings shown in Fig. 5. These rings are used as inserts (see Fig. 6) what means that after connecting them with the tungsten plate the inner ring hole is very precisely bored. Now, using special bolts (M12) the barrel can be assembled and placed on the support (see Fig. 7). What is important is that the tension in bolts should be

about 15 MPa. The half of the barrel is composed of fifteen tungsten plates to which on the both sides silicon detectors have been glued. Between these tungsten plates there are fourteen tungsten plates without detectors.

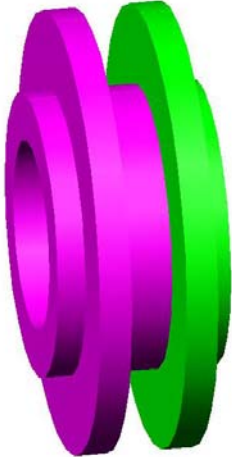

Fig. 5. Rings.

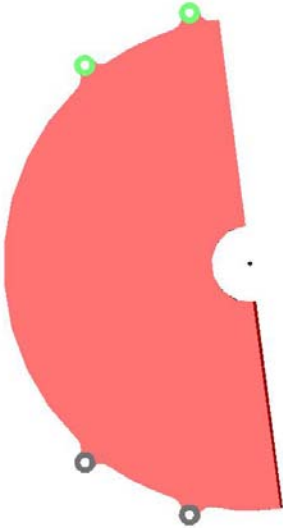

Fig. 6. The tungsten plate with rings.

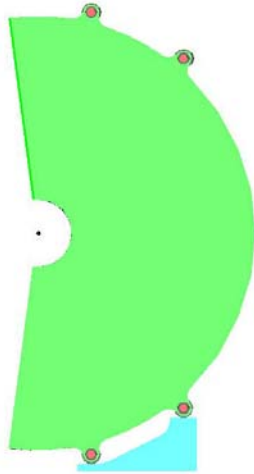

Fig. 7. The half of the barrel.

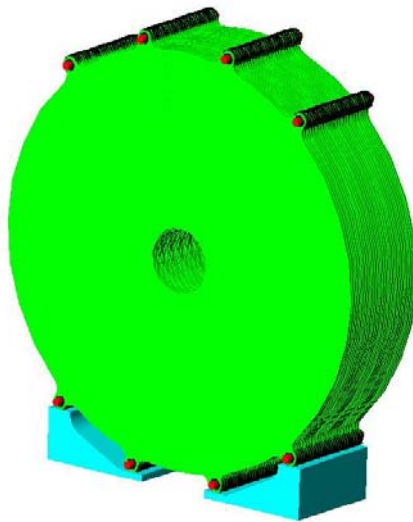

Fig. 8. Two parts of the barrel.

The main advantage of the new design is its simplicity. The structure is composed of very limited number of elements. We have one type of the tungsten plate (see Fig. 3), two types of the rings (see Fig. 5), the special M12 bolts (see Fig. 7) and two supporting elements (see Fig. 8).

It has to be mention that the silicon sensors are glued on the both sides of the fifteen tungsten plates what is a remarkable advantage of this solution because the number of the silicon plane which the position should be monitored is reduced from thirty to fifteen. In addition, the structure fulfills the symmetry condition what is very important from the point of view of thermal deformations.

**4. Results of calculations**

First, we present results of calculations which are for one tungsten plate subjected to the dead load. As can be seen from Fig. 9 the maximal value of the vertical displacement is 0.00024 mm. This value of the displacement suggests that the tungsten plates are enough stiff and should be used to support the silicon planes.

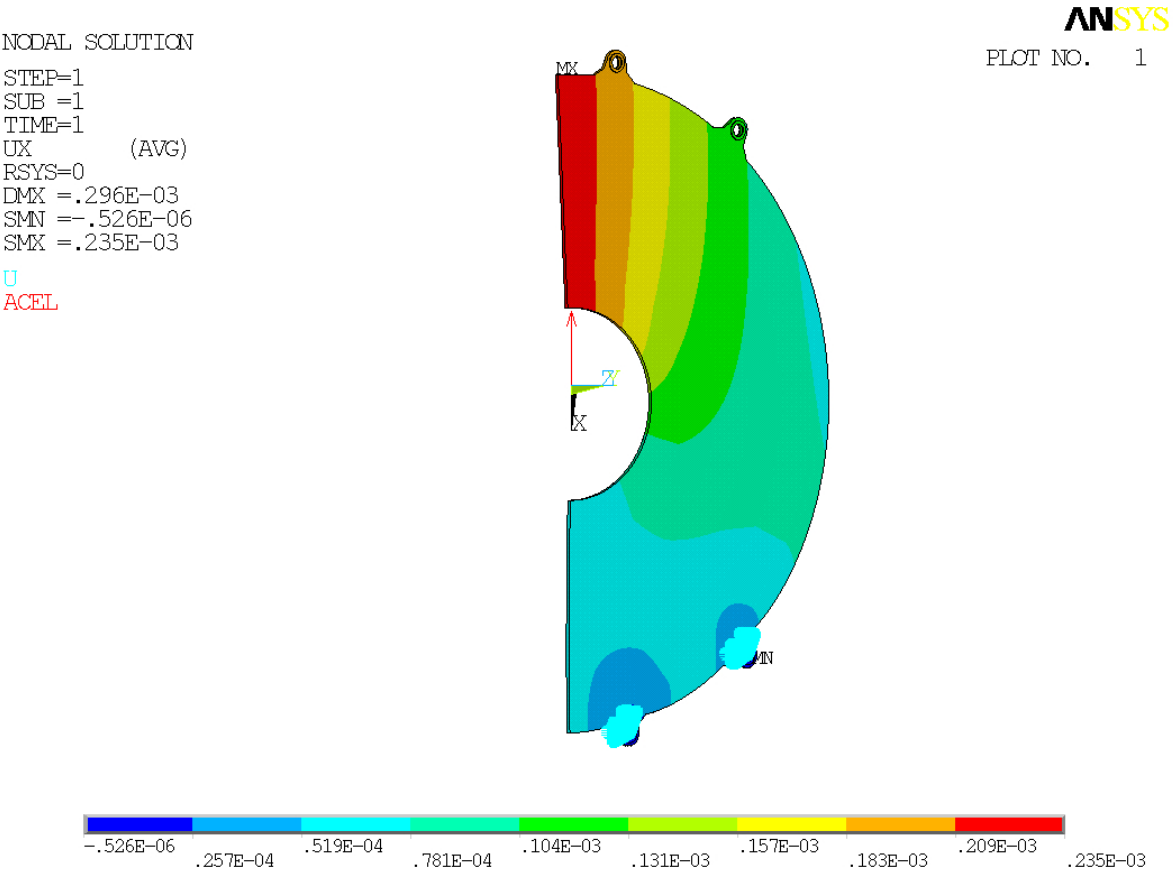

Fig. 9. One tungsten plate subjected to the dead load.

For the half of the barrel supported at four points, values of vertical displacements are shown in Fig. 10. The maximal vertical displacement is about 0.04 mm. We can use such a support when the detector is transported. The deformation of the structure can be reduced nearly six times using six supporting points or more than one hundred times using the full length support as it is shown in Fig. 11 and Fig. 12, respectively.

NODAL SOLUTION

STEP=1  
SUB =1  
TIME=1  
UX (AVG)  
RSYS=0  
DMX =.375141  
SMN =-.005387  
SMX =.037917

U  
ACEL

ANSYS  
PLOT NO. 1

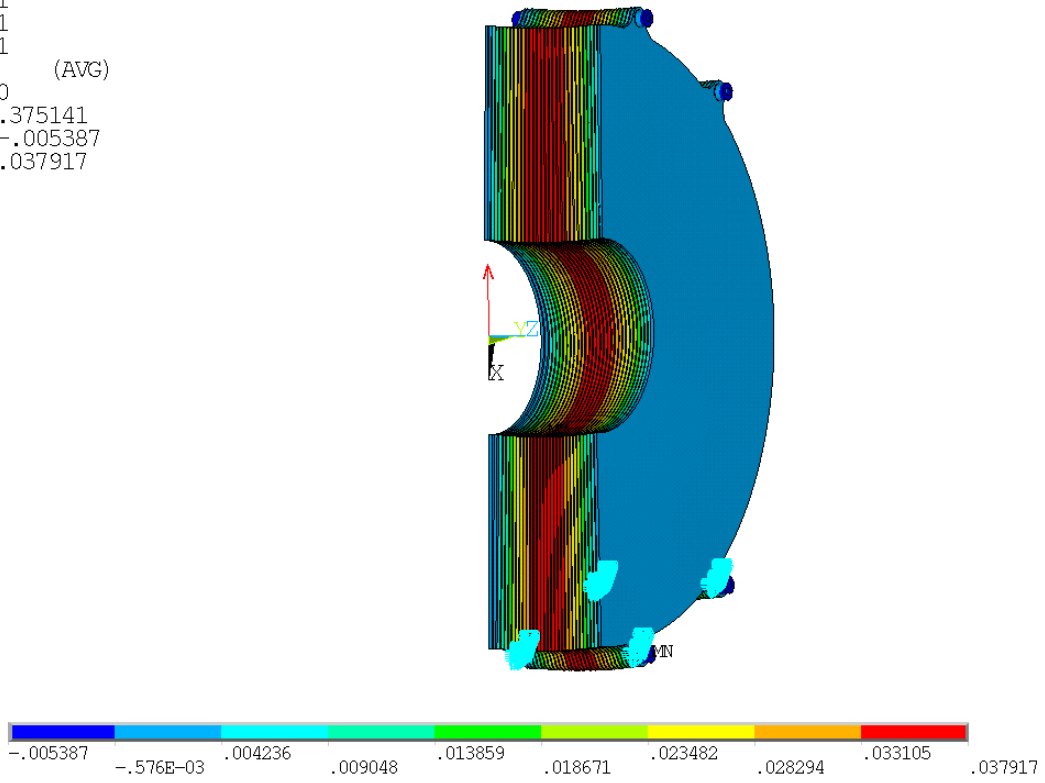

Fig. 10. The half of the barrel supported at four points.

NODAL SOLUTION

STEP=1  
SUB =1  
TIME=1  
UX (AVG)  
RSYS=0  
DMX =1.663  
SMN =-.005642  
SMX =.006817

U  
ACEL

ANSYS  
PLOT NO. 1

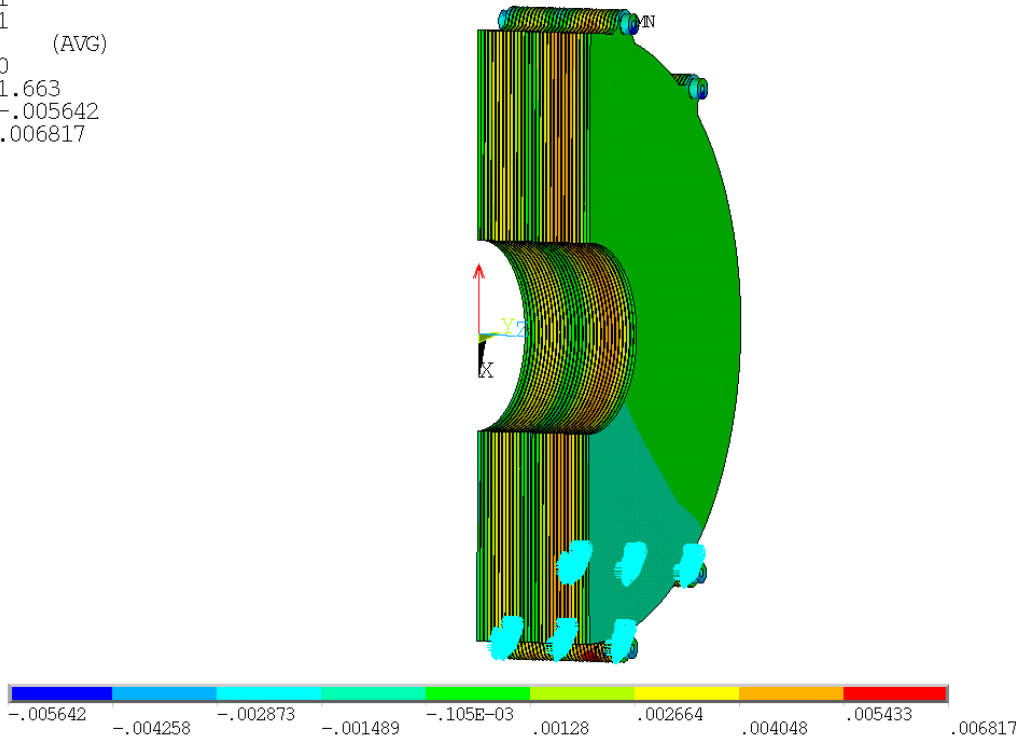

Fig. 11. The half of the barrel supported at six points.



```

NODAL SOLUTION
STEP=1
SUB =1
TIME=1
UX      (AVG)
RSYS=0
DMX =.321381
SMN =-.781E-03
SMX =.254E-03
U
ACEL

```

ANSYS  
PLOT NO. 1

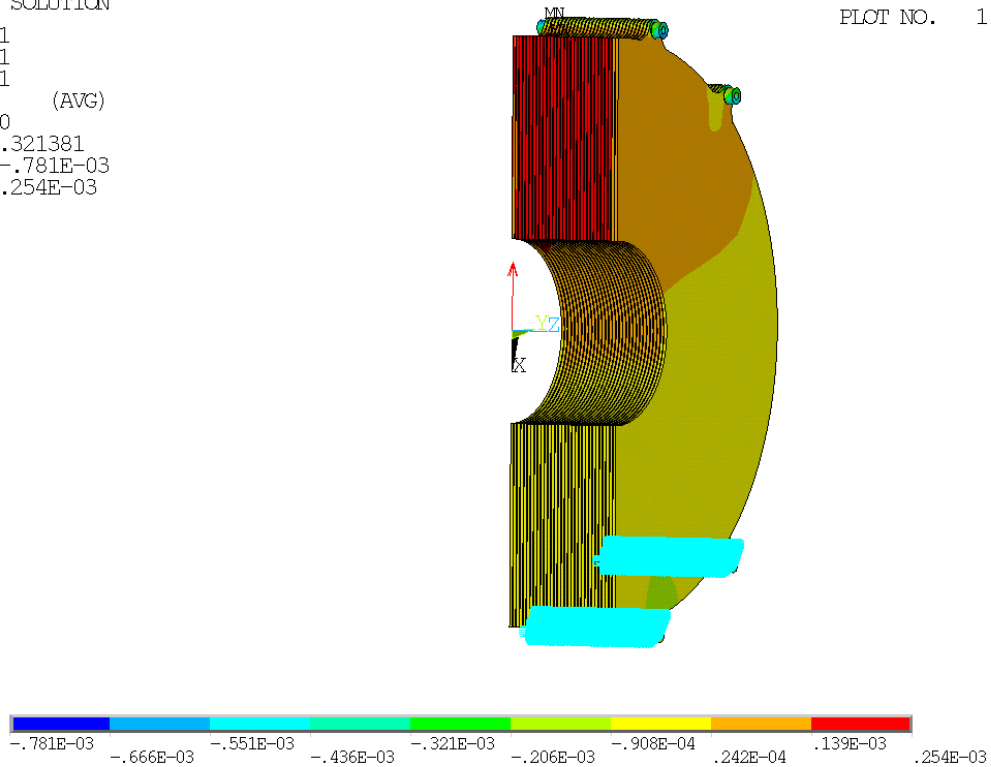

Fig. 12. The half of the barrel supported along the full length.

## 5. Conclusions

From the presented above results of calculations we have proved that the proposed structure can be accepted from the point of view of its stiffness. Moreover, the mechanical design is very simple and has many advantages. It fulfills the condition of the symmetry and we have reduced the number of the silicon planes which the positions have to be monitored by factor of two.

## Acknowledgement

This work was partly supported by:

The Commission of the European Communities under the 6<sup>th</sup> Framework Programme “Structuring the European Research Area”, EUDET program: Detector R&D towards the International Linear Collider, contract number RII3-026126.

## References

1. TESLA Technical Design Report, DESY 2001-011, ECFA 2001-209, March 2001;  
H. Abramowicz et al., IEEE Transactions of Nuclear Science, 51 (2004) 2983;  
R&D for ILC – Detector, Instrumentation of the Very Forward Region, The Forward  
Calorimetry (FCAL) Group, DESY PRC R&D Report 02/01, April, 2006,  
Large Detector Concept, LDC outline document: <http://www.ilcldc.org/documents> .
- 2 International Linear Collider: <http://www.linearcollider.org/cms> .
- 3 A.Stahl, *Luminosity Measurement via Bhabha Scattering: Precision Requirements for the Luminosity Calorimeter.*, LC-DET-2005-004, April 2005.