

Report No. 1993/PH

**Silicon sensors for the LumiCal
for the
Very Forward Region**

J. Błocki, W. Daniluk, W. Dąbrowski¹, M. Gil, U. Harder², M. Idzik¹, E. Kielar,
A. Moszczyński, K. Oliwa, B. Pawlik, L. Suszycki¹, W. Wierba, L. Zawiejski

on behalf of the FCAL collaboration³

Abstract

The silicon-tungsten calorimeter LumiCal, located in very forward region of the future detector at the International Linear Collider, is proposed for the precise luminosity measurements based on the Bhabha scattering process. For this purpose, the precise measurement of the scattering polar angles is crucial. A silicon-tungsten sandwich calorimeter with fine-segmented silicon sensors has been designed for this purpose. This paper describes two slightly different designs of silicon sensors for the LumiCal based on available silicon technologies and especially on the possibility of cutting silicon wafers on curved lines.

¹ AGH, University of Science and Technology, Cracow, Poland

² DESY, Zeuthen, Germany

³ list of authors can be found: <http://www-zeuthen.desy.de/ILC/fcal/>

1 Introduction

In the future detector for the International Linear Collider ILC [1], the very forward region is a particularly challenging area for instrumentation. The LumiCal detector [2] is expected to give the required precision of 10^{-4} luminosity measurement and to extend calorimetric coverage of small angles from 27.5 to 83.1 mrad. The luminosity measurement will be based on detection of Bhabha event rate. The precise measurement of the scattering polar angles requires fine segmented silicon sensors [3] and an ultimate precision in detector mechanical construction and metrology [4].

2 Mechanical Structure

The two LumiCal detectors will be built as the silicon-tungsten sandwich calorimeters. Segmented silicon sensors are interspersed into tungsten half-disks of one radiation length (3.4 mm). The gap for sensors is above 2 mm being a reasonable space for standard assembly technologies. A possible mechanical structure is shown in Fig. 1.

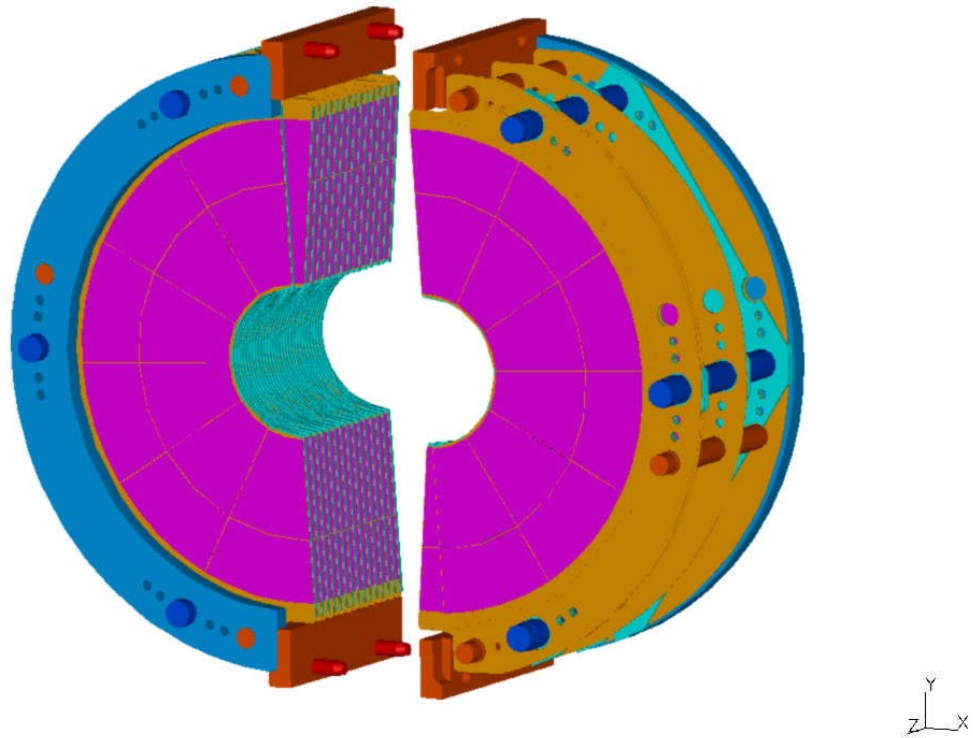

Fig.1 The proposed mechanical structure of the one LumiCal a bit more details.

The two half barrels can be clamped on the closed beam pipe. The position of the two parts of the detector with respect to each other will be fixed by the help of precise pins placed at the top and bottom of each C shaped steel frame. The latter stabilizes the structure and carries the heavy tungsten disks by the blue bolts. The light silicon sensors are glued to the ceramics support and positioned by the red bolts. The frame for sensors is decoupled from the tungsten disk support; hence it does not suffer by gravitational sag due to the tungsten disks. Optionally, we are investigating the possibility to glue the silicon sensors directly to the tungsten absorber surface with some insulation [5]. The silicon sensors of 300 μm thickness are glued on a 1 mm thick ceramic support or directly to the tungsten surface and a 0.7 mm space is left for bonding. Thin glass with aluminium readout traces is foreseen to fan out the

signals from pads to the charge sensitive preamplifiers. The place for readout electronics, connectors and cooling is foreseen at the outer radius of the calorimeter as shown in Fig. 2.

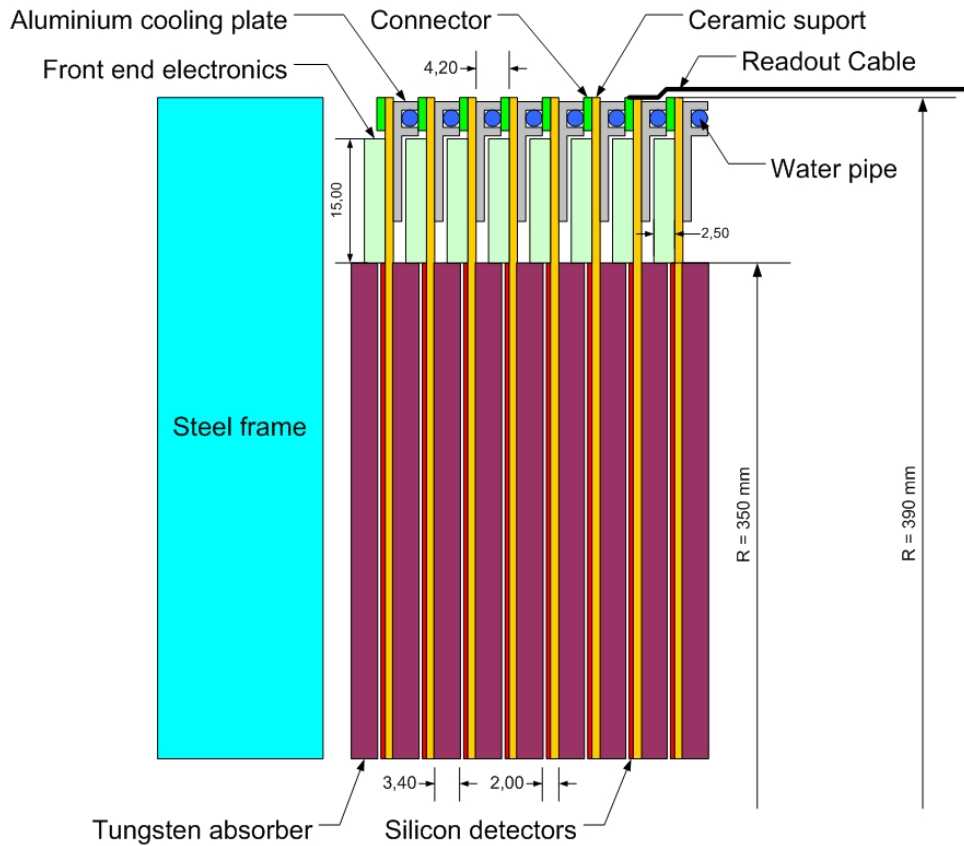

Fig. 2 The cross section of the LumiCal.

The thin water pipes goes around the outer detector diameter are pressed into aluminium profiles glued to the bottom side of ceramic sensors support.

2 Silicon sensors

The proposed LumiCal detector will consists of 30 layers of tungsten of 1 radiation length thickness and $300\ \mu\text{m}$ silicon sensors layers. The sensitive region extends from 80 mm to 350 mm in radius. Each such layer will include 48 azimuthal sectors. The sector will be segmented into 96 radial strips with a constant pitch. The sensor plane will be built from a few tiles because the current technology is based on 6-inch wafers and at the moment it is unclear if and when larger wafers will be available.

The tiles of the silicon sensors will be glued to a thick film support ceramic plate or directly to a tungsten surface with some insulation. Reference marks are foreseen on the detector surface for precision positioning. The layout of the sensors and the mechanical design of the calorimeter does not allow sensor to overlap. To reduce of the impact of the gaps odd and even planes are rotated by 3.75° . The silicon diodes will be usual planar high resistive silicon sensors.

The Fig. 3 shows a half plane of the proposed structure of 24 sectors and 96 cylinders. To cover it 36 silicon tiles with 2304 pads are needed.

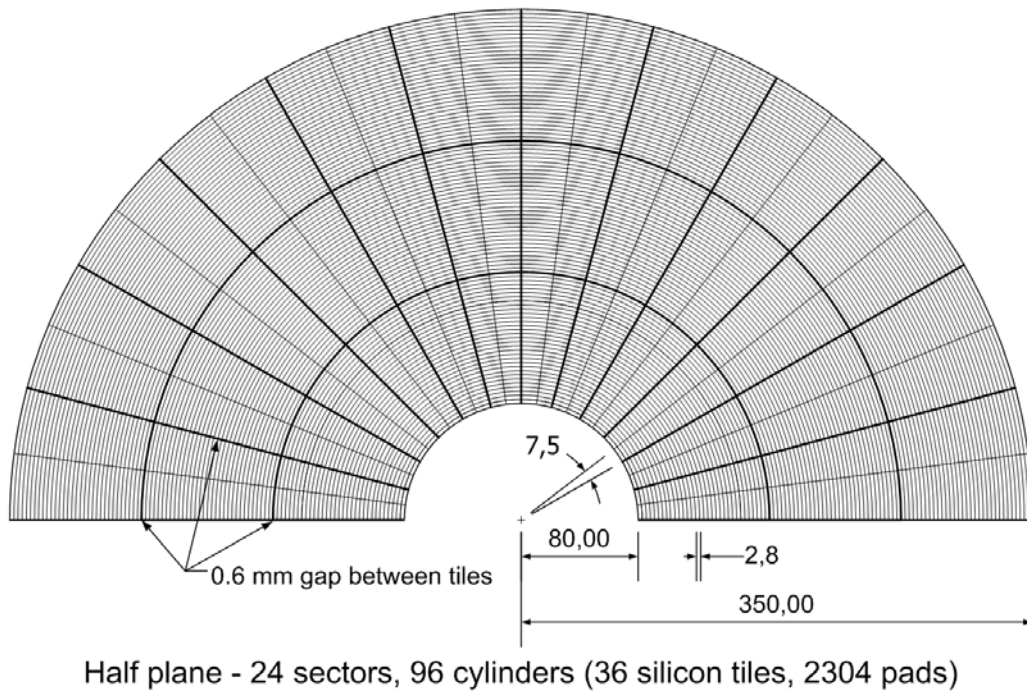

Fig. 3 The proposed segmentation of the silicon sensor half plane.

Figure 4 shows the design of two azimuthal sectors with details on the sensor segmentation proposed for LumiCal. The gap between radial tiles and between every two sectors is foreseen to be 0.6 mm as shown in Fig. 3 and Fig. 4. Counting also the guard rings of 0.2 mm width the inactive area around the tiles has a width of ~ 1 mm. This gap width has to be taken into account in the MC simulations. The azimuthal gaps are staggered by rotation for odd and even layers of the detector. The radial gaps will overlap in depth in that particular design. If the MC simulations will show important effects due to the overlapping radial gaps, we foresee a different division the sectors of the silicon detector to the tiles for the odd and even layers. This will cause the necessity to have four set of masks for the detector production.

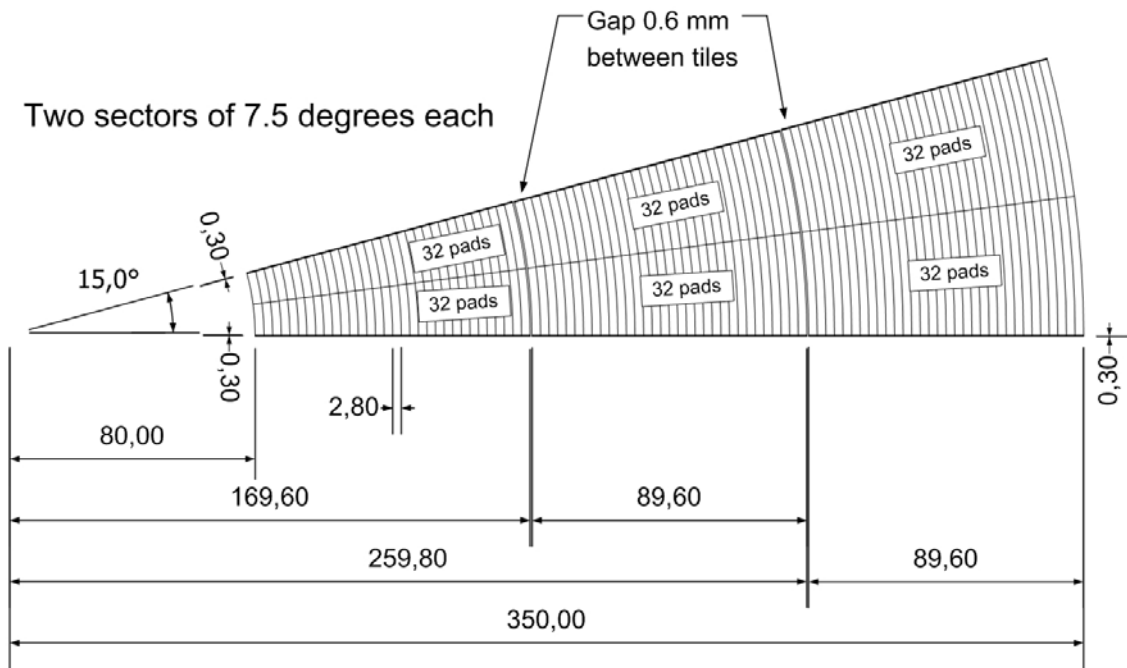

Fig. 4 Two azimuthal sectors consist of three silicon tiles.

To manufacture the sensors designed above, it is necessary to cut the silicon tiles on curved lines (arch). This is not clear yet if such a process is technologically possible at low cost.

We have prepared a slightly different solution without the necessity of curved cutting shown in Fig. 5. The disadvantage of this design is that 4 pads out of 96 in each sector will have a different shape as is shown in details in Fig.6, which may complicate the reconstruction algorithm. This geometry has not been simulated yet.

The capacitance of the pads varies from 10 pF for the pad close to the beam pipe to 45 pF for the outer pad.

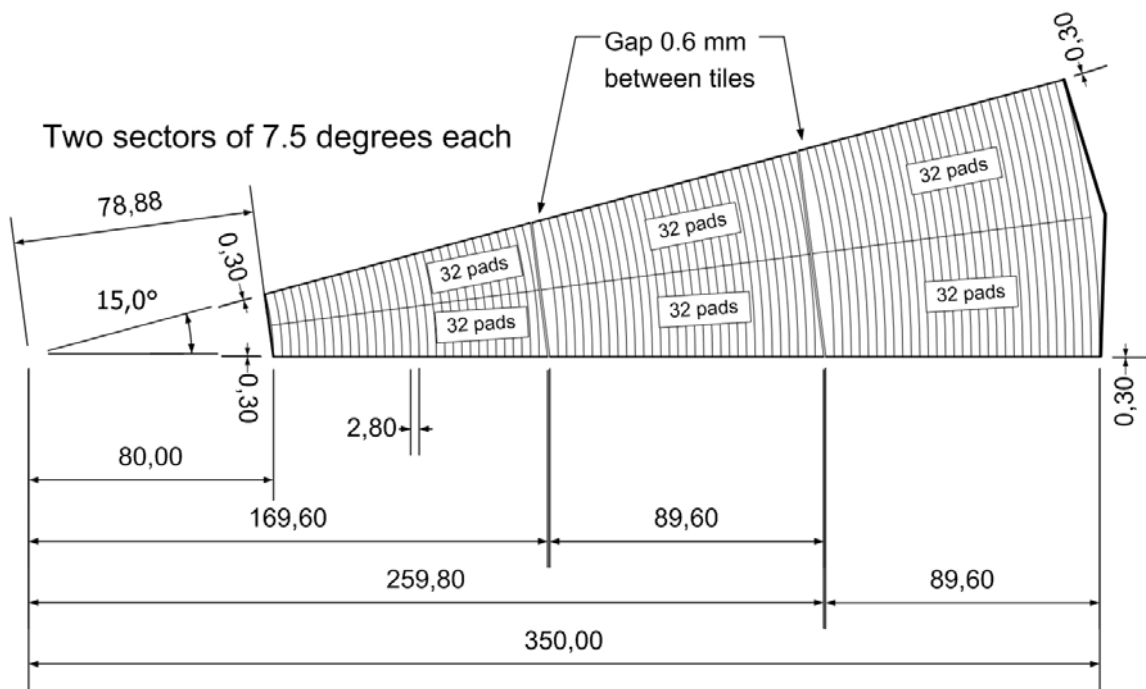

Fig. 5 Two azimuthal sectors with straight cut lines of detector tiles.

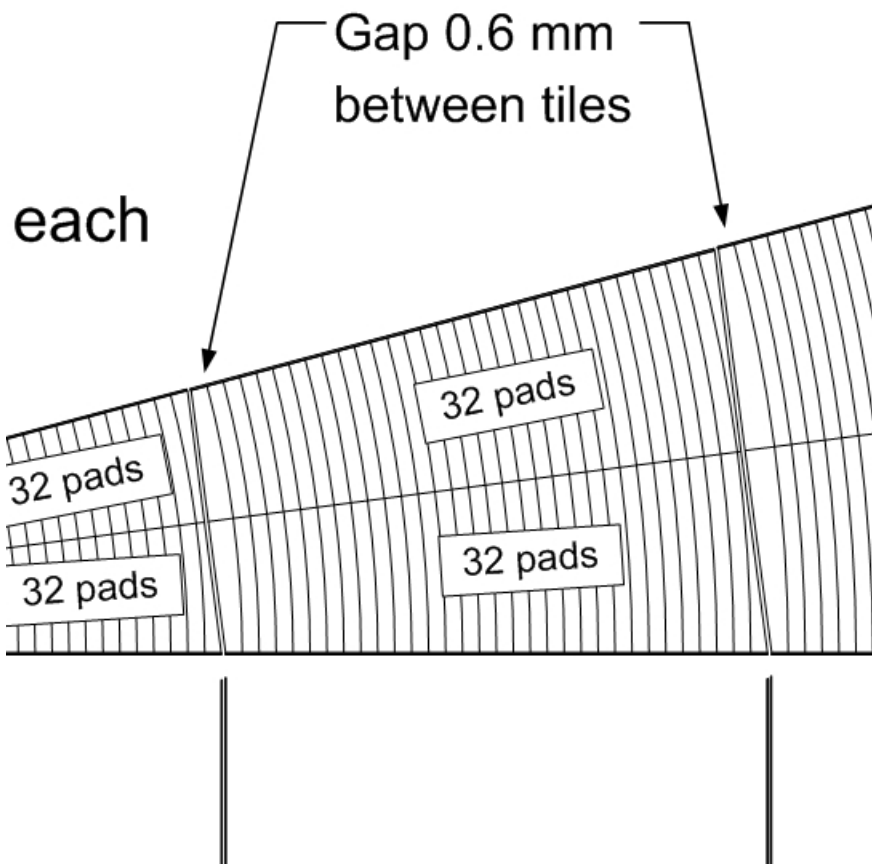

Fig. 6 Detailed view of pads with different shape

The Figure 7 shows the proposed placement of the sensors tiles on the area of a 6 inch wafer. Two different set of masks are necessary to produce the silicon sensor tiles.

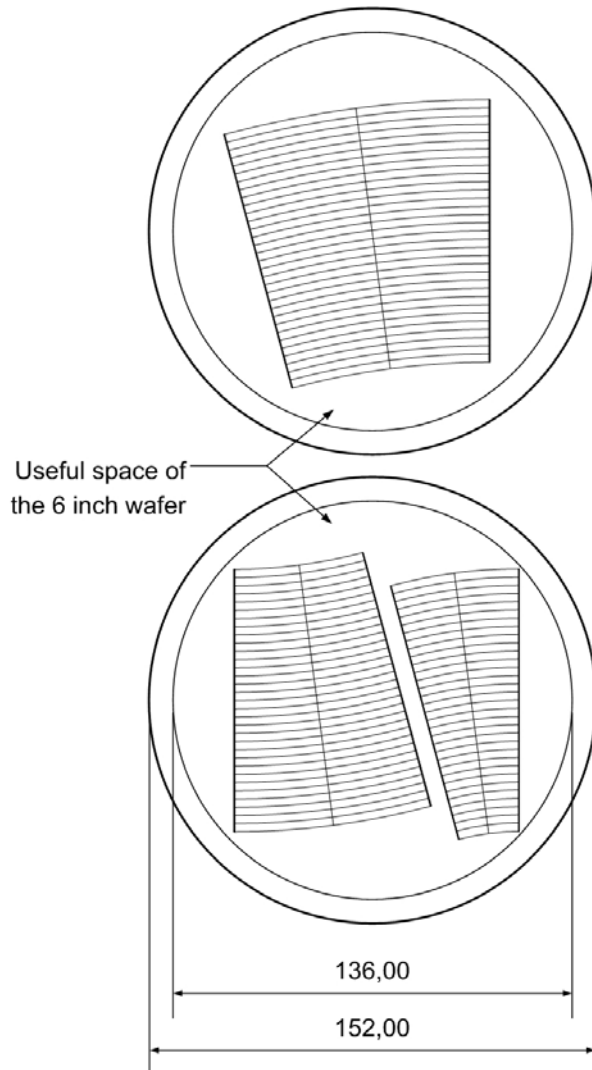

Fig. 7 The placement of the sensors tiles on the useful space of the 6 inch wafer.

It is clearly seen that on two 6 inch wafers there is enough space to place tiles of the two sectors of the proposed detector. If, based on MC simulations, we have to switch to the design with different division of the tiles for odd and even planes, i.e. 28 pads for the tile closest to the beam pipe, 32 pads for the middle tile and 36 pads for the last tile, it is possible to place such tiles on the useful surface of two 6 inch silicon wafers. The shift of the azimuthal gaps by the 4 pads pitch ($4 \times 2.8 \text{ mm} = 11.2 \text{ mm}$) seems to be sufficient because the Molier radius for the LumiCal will be in order of 1 cm.

3 Fan out

To readout charge signals from the pads we have designed a fan out covering two sectors. Aluminium traces of $75 \mu\text{m}$ width on a thin ($200\text{-}300 \mu\text{m}$) glass substrate will feed the signal to the outer radius of the detector where the charge sensitive preamplifiers will be placed. To

avoid crosstalk's between adjacent channels, we foresee grounded lines between each two signal lines. In Fig. 8 the design of the fan out is presented for one sector.

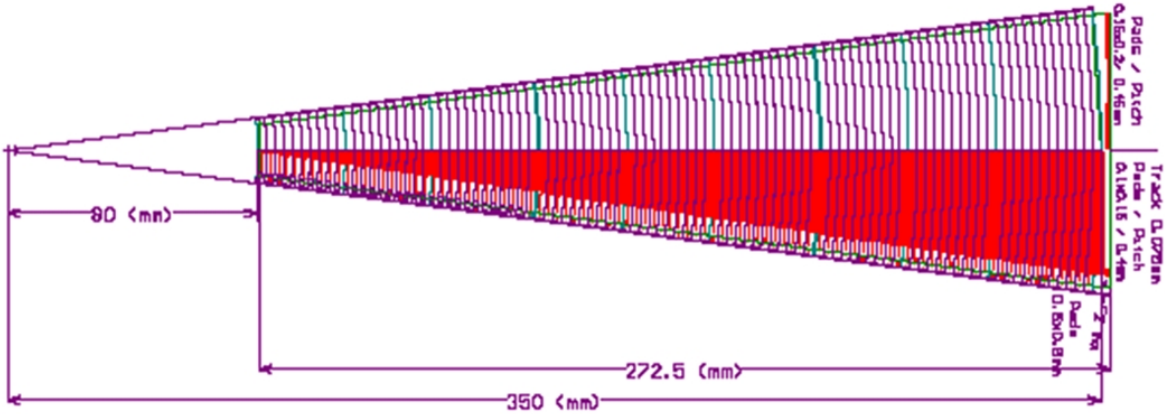

Fig. 8 Layout of the fan out to read out one sector.

The distance between signal and ground traces is 125 μm. The simplified cross section of the fan out structure is shown in Fig. 9.

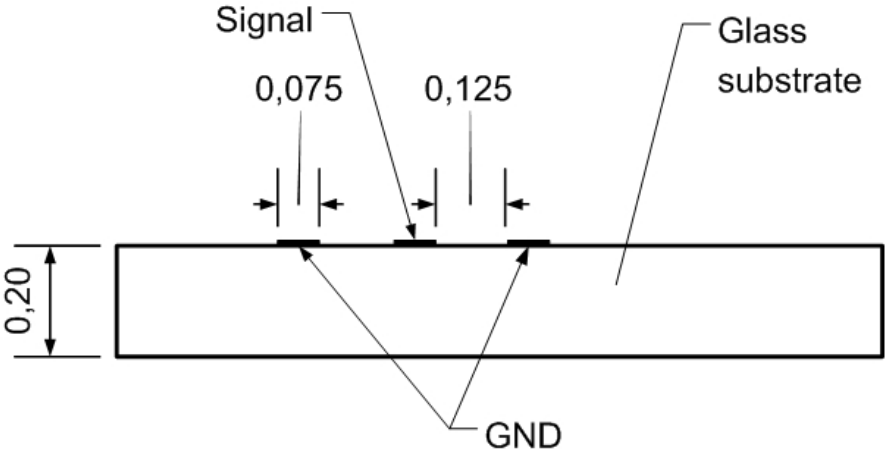

Fig. 9 The cross section of the fan out (all dimensions in mm).

The capacitance of the signal line will be about 0.7 pF/cm. For the smallest pad with a capacitance of ~10 pF the signal trace with length of ~27cm will add ~20 pF, so the input of the charge sensitive preamplifier will see ~30 pF. For the largest pad with capacitance of ~45 pF the capacitance of the signal trace with length of the ~1 cm will be negligible. The capacitances of the different pads coupled to the inputs of the preamplifiers will be in the range between 30 pF to 45 pF.

In Fig.10 all important dimensions of pads, traces and space between traces are shown.

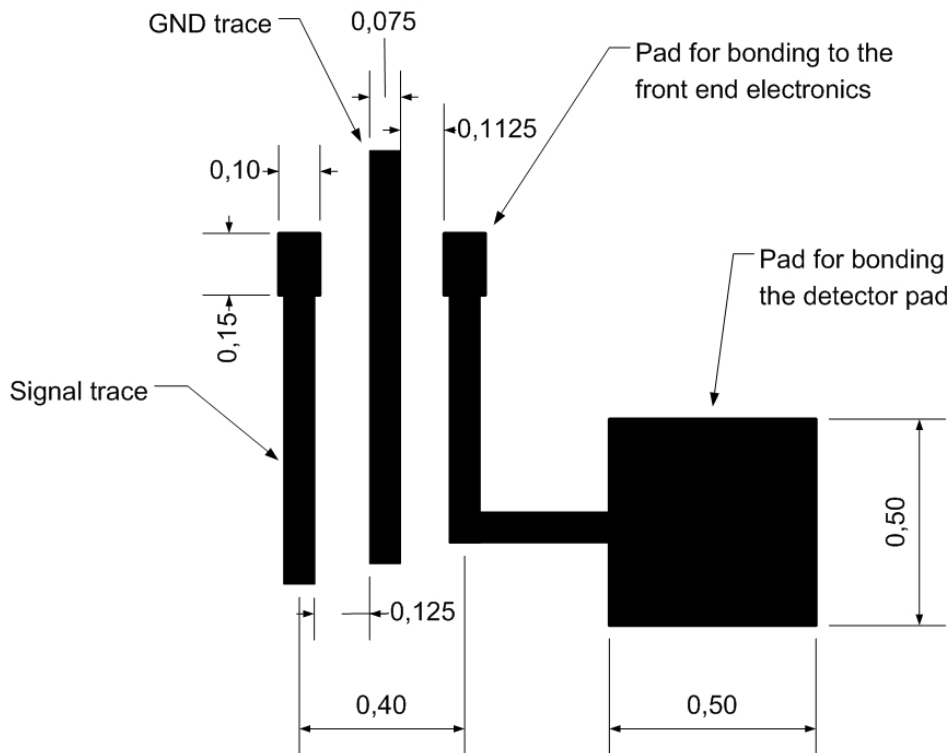

Fig.10 Detailed view of pads and signal traces of the fan out (all dimensions in mm).

The pads for bonding to the front end electronics are sufficient large. The pads for bonding to the detector seems to be too large (but there is enough space) and can be made smaller to reduce the pad capacitance.

4 Summary

The design of the silicon sensors and fan out presented in this paper looks very promising but many details have to be investigated carefully. The new geometry and segmentation have to be implemented in MC simulations. The influence of the proposed design to the precision of the luminosity measurement has to be studied finally, especially the problem of the overlapping radial gaps between sensor tiles. The more detailed discussion on fan out will answer questions on trace capacitance and inductance, crosstalk between channels and breakdown voltage between signal and grounded traces.

Acknowledgement

This work is partly supported by:

Commission of the European Communities under the 6th Framework Programme “Structuring the European Research Area”, contract number RII3-026126.

References

1. International Linear Collider: <http://www.linearcollider.org/cms>
2. TESLA Technical Design Report, DESY 2001-011, ECFA 2001-209, March 2001; H. Abramowicz et al., IEEE Transactions of Nuclear Science, 51 (2004) 2983; R&D for ILC – Detector, Instrumentation of the Very Forward Region, The Forward Calorimetry (FCAL) Group, DESY PRC R&D Report 02/01, April, 2006; Large Detector Concept, LDC outline document: <http://www.ilcldc.org/documents> .
3. A.Stahl, *Luminosity Measurement via Bhabha Scattering: Precision Requirements for the Luminosity Calorimeter.*, LC-DET-2005-004, Apr 2005.
4. J. Błocki et al., *Laser measurement of the LumiCal detector displacement*, Report No. [1985/PH](#) , 2006, IFJ PAN, Cracow, Poland.
5. J. Błocki et al., *A proposal for the mechanical design of the LumiCal detector*, Report No. [1990/PH](#) , 2006, IFJ PAN, Cracow, Poland.